

MB05S thru MB10S

0.5 A Single-Phase Glass Passivated Bridge Rectifiers

Rectifier Reverse Voltage 50 to 1000V



MINI-DIP

Features

- This series is UL listed under the Recognized Component Index, file number E142814
- Ideal for surface mount application
- The plastic material used carries Underwriters Laboratory flammability recognition 94V-0
- Surge overload ratings to 30 amperes
- High temperature soldering guaranteed 265°C /10 seconds at 5 lbs (2.3kg) tension

Mechanical Data

Case: Molded plastic
 Terminals: Plated leads solderable per MIL-STD-202, Method 208
 Polarity: Marked on body
 Mounting Position: Any
 Weight: 0.0044 ounce, 0.125 grams (approx)

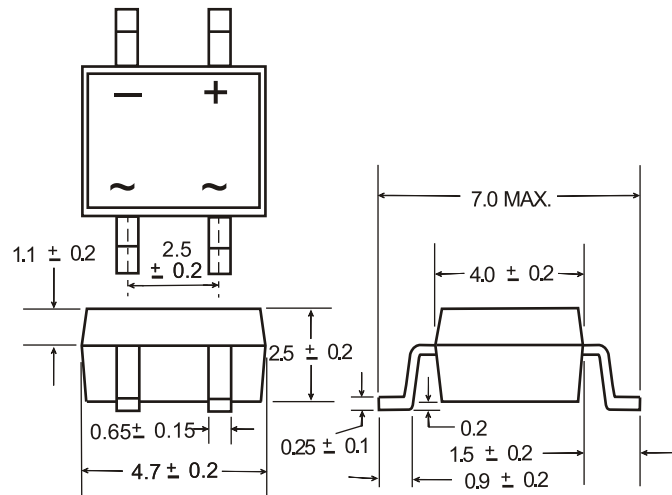

Dimensions in millimeters(1mm =0.0394英寸)

Maximum Ratings & Thermal Characteristics

Rating at 25°C ambient temperature unless otherwise specified, Resistive or Inductive load, 60 Hz.
 For Capacitive load derate current by 20%.

Parameter	Symbol	MB05S	MB1S	MB2S	MB4S	MB6S	MB8S	MB10S	unit
Maximum repetitive peak reverse voltage	VRRM	50	100	200	400	600	800	1000	V
Maximum RMS bridge input voltage	VRMS	35	70	140	280	420	560	700	V
Maximum DC blocking voltage	VDC	50	100	200	400	600	800	1000	V
Maximum average forward rectified output current at TA=40°C	IF(AV)	0.5							A
Peak forward surge current single sine-wave superimposed on rated load (JEDEC Method)	IFSM	30							A
Rating for fusing (t<8.3ms)	I ² t	10							A ² sec
Typical thermal resistance per element(1)	ReJA	110							°C/W
Typical junction capacitance per element(2)	Cj	25.0							pF
Operating junction and storage temperature range	TJ, TSTG	-55 to + 150							°C

Electrical Characteristics

Rating at 25°C ambient temperature unless otherwise specified. Resistive or Inductive load, 60Hz.
 For Capacitive load derate by 20 %.

Parameter	Symbol	MB05S	MB1S	MB2S	MB4S	MB6S	MB8S	MB10S	Unit
Maximum instantaneous forward voltage drop per leg at 0.5A	VF	1.1							V
Maximum DC reverse current at rated TA =25°C DC blocking voltage per element TA =125°C	IR	10 500							μA

Notes: (1)Thermal resistance from Junction to Ambient on P.C.board mounting.
 (2)Measured at 2.0MHz and applied reverse voltage of 4.0 volts.

Rating and Characteristic Curves (TA=25°C Unless otherwise noted)

MB05S thru MB10S

Fig. 1 Derating Curve for Output Rectified Current

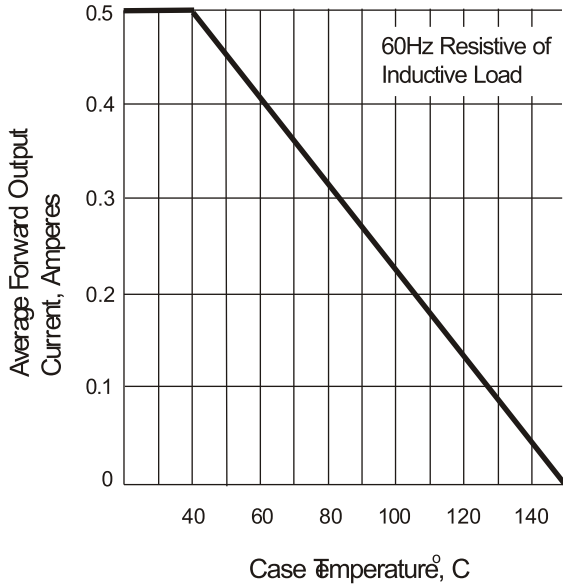

Fig. 2 Maximum Non-repetitive Peak Forward Surge Current

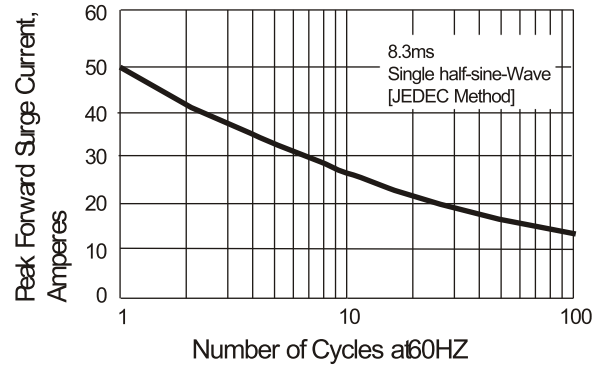

Fig. 3 Typical Instantaneous Forward Characteristics

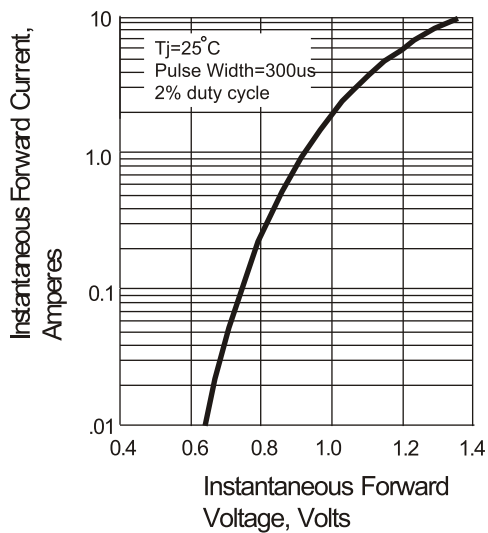

Fig. 4 Typical Revers Characteristics

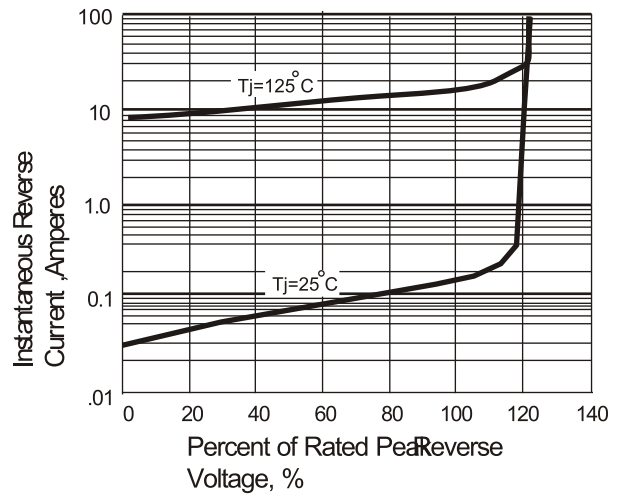

Fig. 5 Typical Junction Capacitance

